

# Challenges with Transmission of data over CATV networks

Frank Koperda  
Farr Farhan

Scientific-Atlanta

## **ABSTRACT**

*In this paper the architectural and design considerations for the development of a network capable of reliable data delivery over shared CATV media are discussed. Potential challenges encountered during the transmission of data over CATV environment are examined. The media access method requirements and some implementation challenges are looked at and analyzed. The coexistence of data, telephone and video services and deployment considerations are also presented.*

## **INTRODUCTION**

Computers are becoming an indispensable item in the US household and business environments. Along with the presence of computers comes the need for their inter-connection to other computers, data banks and information servers. The internet has become the world's largest network, allowing people from almost anywhere in the world to communicate with each other and exchange information. Along with this capability comes the need for inter-connection at higher speeds. On-line service providers and users have always been limited and frustrated by the bandwidth of the telephone modem. Application programmers have also suffered from

this, with their creativity being limited by the bottleneck.

The cable plant is inherently capable of providing very high communication speeds in a rather asymmetric fashion. There is much more bandwidth available in the downstream (to the home) direction than there is in the upstream direction. This asymmetry is surprisingly suitable for the home and small business environments, since the users predominantly retrieve much larger amounts of information than when they send. This property of the cable plant creates a very interesting opportunity for the cable owner, however, there are many challenges associated with providing this capability that we will try to address in this paper.

The first task is to choose a topology that will lead to easy operations and most efficient use of investment. Figure 1.0 represents a likely network topology for the delivery of data services. The network consists of three distinct physical blocks. They include the Master Head-end (MHE) equipment, Distribution Hub (Head-end) equipment and the Home unit. The topology of this network enables the operator to centralize the operations and the location of information serving computers, thus lowering operational and capital costs.

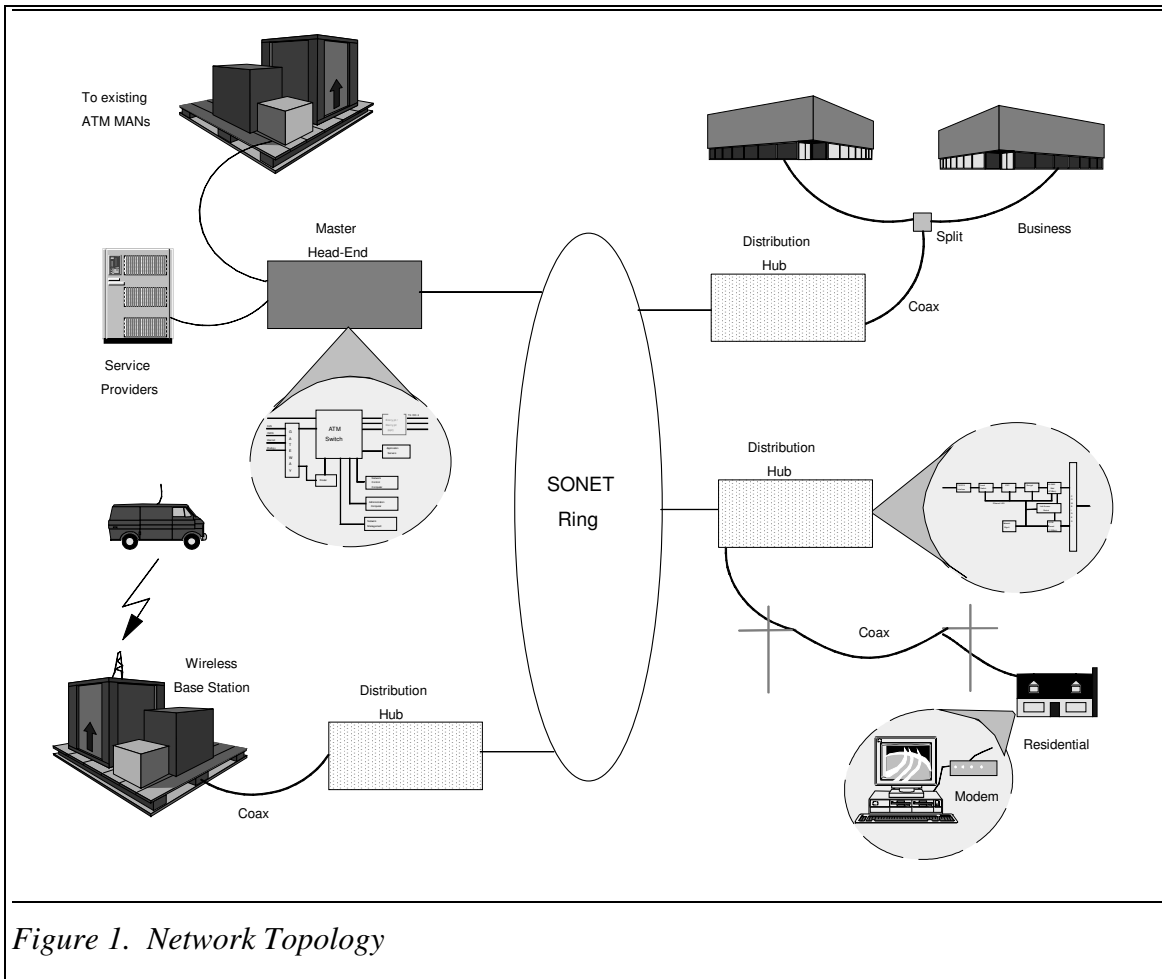

Figure 1. Network Topology

Among the functions likely to be performed at the MHE are billing, level of service authorization, and network operations control. The MHE supports several Distribution Hubs and therefore is a logical point to perform inter-hub switching or routing, as well as serving as a gateway to external networks.

The intended use of this network involves enhancing existing applications such as work-at-home, on-line services and access to the Internet and many other services that will be created as a result of the availability of large bandwidth. The home device should compete effectively against existing modem technology by allowing a user to avoid the cost of a

second phone line dedicated to a modem connection and by enhancing the connection speeds from the typical 14.4 Kb/s to a 1.5 Mb/s rate. The connection between the computer and the modem should preferably be a standard interface (such as 10BaseT Ethernet) to allow ease of connectivity.

The product should also create new opportunities for services such as low cost video-teleconferencing, shop-at-home, and interactive games. New services for on-line applications will include video-clips and access to libraries of CD-ROMs.

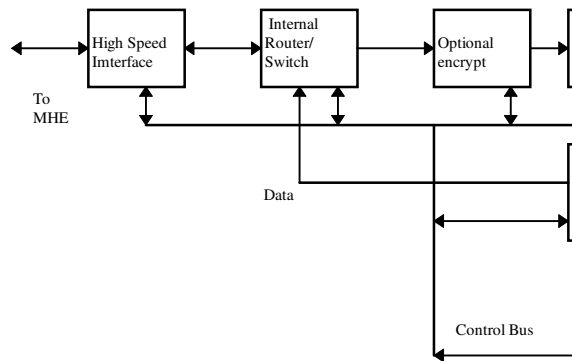

Figure 2. Distribution Hub block diagram

The Master Head-End may connect to several distribution hubs in a large metropolitan area. For smaller systems the Master Head-End and distribution hub may be combined at a single location.

A distribution hub (or head-end) houses a modulator that sends information towards the home using one or more RF modulators (Figure 2). There may also be several upstream RF demodulators to handle the return data. Since many sources may attempt to transmit upstream simultaneously on the shared return path, a Link Access Control mechanism must perform the control of the access method.

The customer premise unit resides at a home or small business and connects on one end to the cable and at the other end to a computer via a standard interface.

The modem acts as a bridge between one or more computers and screens the

traffic to decide which packets need to be forwarded onto the cable network. After deciding that the destination does not reside locally, the bridge terminates the Medium Access Control (MAC) frame and generates cells and forwards the information to its destination.

### USER REQUIREMENTS

The following is a list of requirements expressed by various network planners:

1. Provide LAN-like performance and connectivity as if you were at work.
2. Compatible with a variety of computer platforms and operating systems
3. Ability to connect into the wide area environment
4. Support TCP/IP and connectionless services.
5. Ability to charge based on differing service levels provided.
6. Eventual support of video-conferencing.
7. The upstream and downstream links need to be secure to prevent unauthorized use. Design of an end-to-end encryption scheme is an application layer problem and only the last link needs to be protected.
8. Support voice for use with interactive games.
9. Low cost for residential applications
10. Provide frequency agility to be able to work with other upstream devices and circumvent noise.
11. Prevent a single user from monopolizing a link.
12. Avoid creating another dedicated network management computer.

Run as application on existing platforms.

For the optimum solution over the cable plant each of the requirements above must be closely examined. Most of the above requirements are realizable over existing baseband high-speed networks. The challenge is introduced when the same performance level is expected of the cable plant. There are a number of characteristics unique to the cable plant:

1. The length of the plant spans many miles. Distances of 15 miles from the distribution hub to the neighborhood are quite typical.
2. The plant is highly asymmetric. The available downstream bandwidth capacity is at least ten times greater than that of the upstream
3. The upstream reverse path is highly noisy (ingress)
4. The upstream bandwidth is needed by many services, including telephony, data, interactive video and energy management.
5. The point to multipoint cable plant topology

## **DATA TRAFFIC CHARACTERISTICS**

In order to design a network capable of providing such services, a detailed study

of the traffic characteristics is necessary; it is important that the service provider have a good handle on the traffic growth over a period of several years. The traffic growth presents significant cost and planning implications over the Distribution Hub and MHE and cable plant equipment.

There will probably be several distinct types of data traffic carried to and from the home. The mix of these types will be variable by user, time of day and system. The product should support:

1. On-line services
2. Games
  - Interactive between several users
  - Game show response by a large number of users
3. Video-conferencing
4. LAN emulation for work-at-home applications

Each of these traffic types imposes different requirements on the transport network to ensure the customer receives the desired quality of service. These are given in Table 1.

Type	Peak Down-stream	Peak Up-stream	Characteristic	Access	Latency	Jitter
Video conferencing	384 Kb/s	384 Kb/s	constant	fixed	fixed	low
Games (game show)	50 b/s	-	extremely bursty	large	large	large
Games (interactive)	1 Kb/s	1 Kb/s	bursty	15 ms.	15 ms.	large
LAN Emulation	1.5 Mb/s	1.5 Mb/s	bursty	100 us.	3 ms.	large
On-line Service	1 Mb/s	2 Kb/s	bursty	medium	medium	medium
CD-ROMs	720 KB/s	-	bursty	medium	medium	medium

Table 1. Performance requirements for supported data streams.

### REQUIREMENTS FOR THE ACCESS METHOD

The upstream path is a very bandwidth-limited channel that must work to support the simultaneous needs of the upper layer protocol in transporting a variety of traffic types over a noisy link. The challenge is to provide a means for giving a user all they request at the quality needed, sharing the media amongst many users, and providing the statistics and diagnostics to ensure its reliability.

A connection can be described in terms of bandwidth (bits/sec) needed to be transmitted and received, latency (time to get access to the media), delay (time from sending to receiving), and jitter (variation of arrival times). As can be seen in Table 1, the various applications have different combinations of bandwidth, latency, delay and jitter and any combination of these may be present

simultaneously. These new applications challenge the existing access methods to provide effective transport capabilities.

Traditionally, Local Area Networks (LANs) have not worried about these issues. They typically operate by having a station request access, grab the medium and use it for a packet time and then release the medium. There is no guarantee of the amount of bandwidth that a station can get and no way to keep a user from "hogging" the available bandwidth. Because of the way LANs operate, it is not possible to have a deterministic connection.

The most common access method for LANs is known as Carrier Sense Multiple Access with Collision Detection (CSMA/CD) which is a technique that listens before transmitting and listens while it is transmitting to ensure that no other station interferes. For a lightly loaded LAN (30%) there is a good probability that the LAN can handle time critical data. As the link utilization increases, the probability of a collision increases and re-transmissions become necessary. This means that the

receiver will see variations in the scheduled arrival time (jitter). Long packets will also cause jitter because a station may want to transmit, but it must wait until the current packet has completed transmitting. The longer the allowable packet length the greater the potential jitter.

Providers of this service would like to offer a tiered service which would be priced based on resource utilization. A higher tiered connection might be a video-conference at 384 kb/s and a low tiered service might be an interactive game. This requirement of access method means that both a minimum guaranteed bandwidth and a maximum bandwidth limit must be placed on a stations connection(s).

The last major requirement of the access method is it that it must operate efficiently. The metrics of efficiency are a balance between maximum link utilization (bits/second transferred), cost (\$/mega Hertz), and bit error rate (BER). Overhead for a Forward Error Correction (FEC) code takes away from the bandwidth but reduces the need for re-transmission. More complex modulation schemes that are capable of providing more bits per Hertz are desirable but are more costly and have a higher BER for a given signal-to-noise ratio (SNR).

Work is being done in various standards committees to solve many of these issues. This work is aimed at enabling product offerings from many manufacturers, thus forcing down the equipment prices. Among the organizations looking at these issues are the IEEE

802.14 committee, ATM Forum and DaVIC.

Among the many possible solutions being considered are modifications to the IEEE 802 protocols so that an application can negotiate the characteristics of the needed connection with the network. Centralized control of station access will be required to ensure that a user does not utilize the shared link beyond its authorized service level. Security will be needed on the upstream and downstream links to ensure that other stations cannot use information destined for another station. Forward error correction must provide a link performance of 1 error in  $10^8$  bits.

## **NETWORK LOAD PROJECTIONS**

The following is the projected analysis of the amount of data that the network will be expected to handle. The assumptions are:

- 100,000 subscribers /cable system
- 5 hubs / master head-end
- Erlang calculations are based on 1% call blocking probability
- 64-QAM @ 27 Mb/s
- Burst mode QPSK upstream @ 1.5 Mb/s
- Downstream link utilization 95%
- Upstream link utilization 80%

Year	Per Distribution Hub Downstream / Upstream		Per Master Head-End Downstream / Upstream	
1	6.5 Mb/s	.8 Mb/s	33 Mb/s	4 Mb/s
2	11.6 Mb/s	3.2 Mb/s	58 Mb/s	16 Mb/s
3	23.7 Mb/s	7.3 Mb/s	119 Mb/s	37 Mb/s
4	76 Mb/s	25.9 Mb/s	380 Mb/s	130 Mb/s
5	116 Mb/s	45.6 Mb/s	580 Mb/s	228 Mb/s

Table 2. Network Load

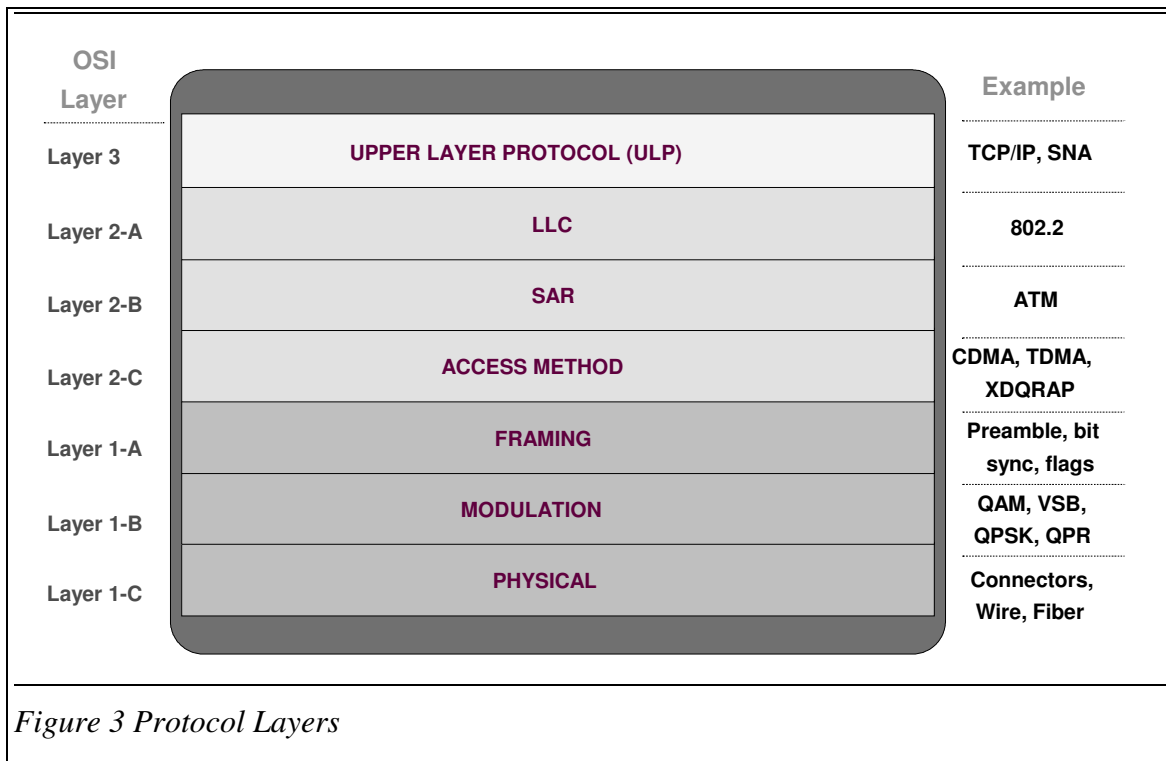

Figure 3 Protocol Layers

Projection

## REVERSE PATH ISSUES

### Working in a noisy environment

The existing cable plant was not originally optimized with the intention of one day providing the interactive video, data and telephony services. This has created a challenge for the equipment providers and service providers. The ingress from off-the-air signals into the drop is one of the largest sources of interference. Energy is coupled in through open terminations and impedance mismatches at the drop cable and is funneled through to the head-end receivers. Other sources of interference and impairments are thermal noise and non-linearity of the reverse active equipment.

Ingress corresponding to signals from short-wave broadcasts and two-way radio signals is observed as relatively stationary narrow-band interference on the cable return. Transient, impulsive impairments are caused by both natural and man-made sources such as lightning, industrial and home appliance noise sources.

The reverse link must be able to maintain a minimum level of performance ( $10^{-8}$ ). Long term performance is indicated by Bit Error Ratio (BER), which is the probability of observing a bit-error over a very long observation time. In a data transmission world, large BER's result in data re-transmission or failure. The effect on the user is the perception of very slow response times.

A robust cable data transport solution must address both of these issues:

1. The stationary interference is overcome by building dynamic frequency agility into the reverse modulators and demodulators. The problem becomes more challenging as the reverse bit-rate increases, since the number of potential users and the amount of proportional occupied spectrum increases. At T1 rates (1.544 Mbps), approximately 1 MHz of spectrum has to be available to allow dynamic re-tuning. Building cost-effective hit-less frequency change-over schemes is challenging.
2. The impulse hits can be overcome by either using Forward Error Correction (FEC) schemes on the data or by just putting the burden onto higher layer protocols such as Transmission Control Protocol (TCP). Forward Error correction techniques can provide correction in small blocks of data. These blocks could be as small as one symbol. Thus, if the impulse hits are relatively long, FEC will not help and other alternatives must be used.

### Coexistence with other Services

Currently the only available scheme for enabling coexistence of various service types on the RF plant is for each service type to own its own unique upstream and downstream channels. By using this inherent property of the cable plant, we can guarantee coexistence. Consequently, it is necessary to know the RF bandwidth requirements of each of those (digital) services in each direction of traffic, and their required quality of service parameters, such as tolerance to various types of errors, delay and jitter. Also, knowledge of the RF actives and passives, specifically their gain versus

frequency, their phase (group delay) versus frequency and gain versus level behavior is necessary, of course during initial system commissioning and later for dynamic transmission control. The ability to control the power levels of the various reverse transmitters for optimum signal reception and minimum interference is another challenge. A high level carrier from inside the home may have undesirable distortions on the lower end of the forward spectrum and potentially overdrive the reverse amplifiers and optical lasers. On the contrary, too low of level will not provide the needed Carrier-to-Interference ratio. Certainly, the future migration of various service elements at the home into a more integrated platform will alleviate some of these problems.

## **NETWORK MANAGEMENT**

According to the International Standards Organization (ISO), network management consists of five subsystems, Fault management, Configuration Management, Accounting, Performance Management, and Security.

Network management must be viewed as an enterprise requirement and not just a product requirement. The effective management of an enterprise network requires easy and open interfaces to each network element managing agent, intelligent knowledge of the capabilities and needs of each network element and finally the knowledge all network element inter-dependencies.

The common management protocol, being currently considered by some

industry leaders, is the Simple Network Manager Protocol (SNMP). SNMP is part of the TCP/IP protocol suite. SNMP provides a common mechanism for the communication of management information among network elements and element and network managers. Some the required activities for the proper management of a network were alluded to in the previous section. The discussion of reverse path spectrum management and cable plant management fall under configuration management and performance management.

A network management platform consists of:

### **Fault Management**

Fault management is the process of isolating faults within a network and reporting the faults and the cause of the faults to the appropriate staff. The Network Management Platform (NMP) should prioritize all critical data and filter all non-critical data. This task requires the NMP to understand the network topology and correlate events from a number of different element managers.

### **Configuration Management**

Configuration management consists of all activities related to the management of critical resources. For the cable plant, these activities include the provisioning of all modulators, demodulators, RF spectrum and amplifiers as well as digital equipment.

### ***Spectrum Management***

Spectrum Management is a form of Configuration Management unique to the

cable plant. As soon as two-way digital services are deployed on the plant and as soon as reverse traffic start to build up, so will the need for intelligent management of the spectrum. The effective management of the reverse spectrum to assure efficient utilization, management and cohabitation of services in the reverse link, will enable the service provider to maximize its revenues and minimize its operational costs. The ideal reverse spectrum management system is capable of monitoring the performance of the reverse spectrum and dynamically making optimum spectrum assignment decisions. The ideal "Reverse Spectrum Manager" must be able to retrieve link performance data in both directions from the various RF transmission equipment on a given plant, know the performance and RF bandwidth requirements of each service type, and be able to command the modulators and receiving demodulators to re-tune to various RF channels at the optimum power levels.

### **Accounting**

Accounting consists of the entire process of service request authorization, billing and bookkeeping. The accounting subsystem must maintain a complete and up-to-date list of authorized users, against which service requests are compared, validated and authorized.

### **Performance Management**

Performance management is the process of analyzing the quality of the network. The data gathered allows the network manager to be proactive in alerting maintenance staff prior to any system degradation which could affect service.

### **Security Management**

Since network management serves as a platform with full control and access to critical system functions and data, system access security is a key factor in the design of any network manager. The NM must give the system administrator the ability to flexibly assign privileges to system users.

Another aspect of security management falls in the realm of signal security and access authentication. This aspect is of crucial importance in a cable topology. The downstream broadcast nature of cable, as well as ease of physical accessibility makes the plant vulnerable to unauthorized users. Scrambling and encryption are techniques being used today to provide conditional access and prevent eaves-dropping. The ideal network management system would have full control of all accesses and will be able to detect unauthorized accesses.

### **CONCLUSION**

In this paper we presented some important issues concerning the offering of data services over cable TV. Network scalability for ease of growth, robust reverse access and modulation schemes, spectrum management, secure links, interference management and in general network management are of utmost importance in the planning of these multi-media networks.